

GS06

GS06

	R808±5-Q900-GS06-3*6-001	R808±5-Q1800-GS06-5*9-001
λ_c nm	808	
λ_c nm	±5	
Bar W	150	200
Bar	6	9
Bar mm	~0.6	
FWHM nm	<5	
Bar (W/A)	>1.0	
FWHM °	8	
FWHM °	12	
nm/	~0.3	
%	>48	
I_{th} A	<27	<27
I_{op} A	<170	<170
V_{op} V	<2	
%	<0.8	
μs	<300	
Hz	<30	
热学参数		
	0~45	
	0~55	

- 1.
- 2.
- 3.
- 4.

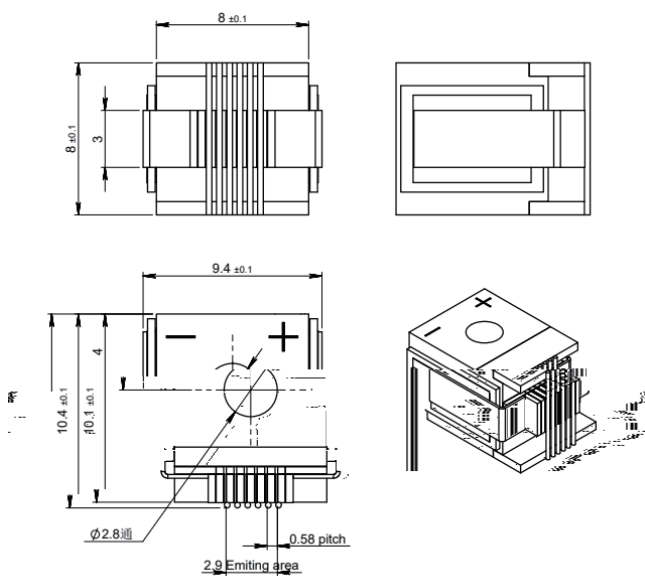
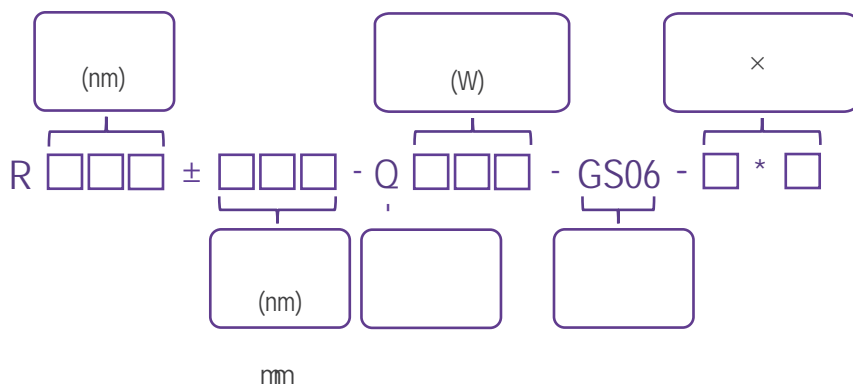

R808±5-Q900-GS06-3*6

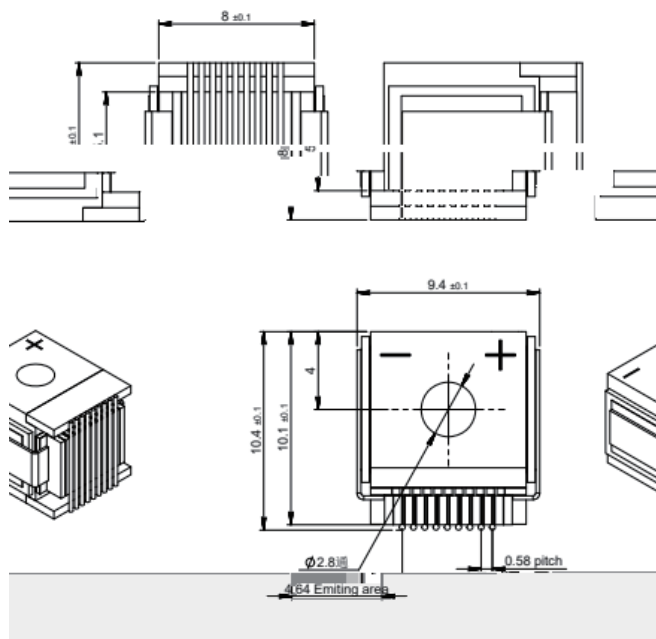

R808±5-Q1800-GS06-5*9

